

# Wildlife Plantings And Practices

CIRCULAR ANR-485

ALABAMA COOPERATIVE EXTENSION SYSTEM, ALABAMA A&M AND AUBURN UNIVERSITIES

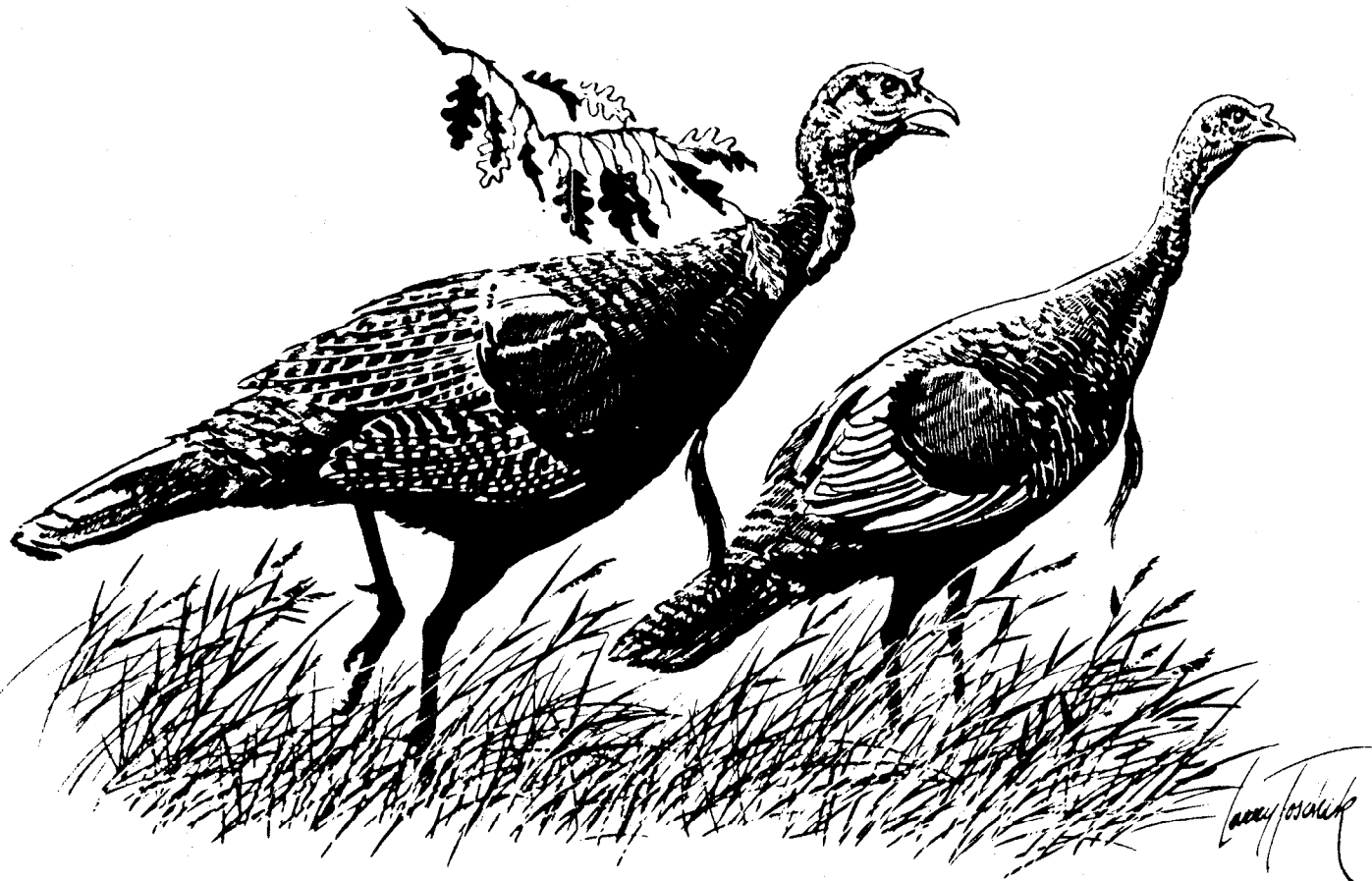

# Wildlife Plantings And Practices

## Planting For Wildlife

Three of the most important requirements for game and non-game wildlife are food, water, and shelter. Increasing or decreasing wildlife populations is primarily a matter of altering these basic requirements.

Water seldom limits wildlife populations in Alabama, so there is little need to manage water except to attract waterfowl. But, the lack of shelter may limit wildlife numbers. Therefore, whenever possible, preserve vegetation on sites such as bays, branches, fence rows, hedge rows, and old house sites. Although wildlife cover can be planted, it is much easier and cheaper to preserve natural cover.

In many areas, food is the main factor limiting wildlife numbers. Under most circumstances, native vegetation provides cover and is the best food for our native wildlife. Listed on pages 5 and 6 are some native plants which are important to wildlife. Every attempt should be made to preserve and encourage the growth of these native food plants.

The most economical food plots can be made by simply liming and fertilizing natural foods. Adding fertilizer and lime (if needed) will also increase the nutritive value of natural foods. Wildlife, especially deer and turkey, are attracted to fertilized foods.

Under certain circumstances, it may not be possible to manage native food plants. In these cases, use locally available domesticated plant materials. A number of different plantings can be used. The Alabama Planting Guide on pages 7 and 8 lists the varieties that grow well.

Although most plants are listed individually, you may want to plant mixtures of several different ones. If you can only plant one kind, try to stagger the planting dates. Either technique-mixing varieties or staggering planting dates-will provide a longer period of food availability.

Generally, wildlife is found at an *edge*, where two or more kinds of vegetation meet. The variety of plants is greatest at edges, so more food items and cover materials are available. Manage feeding areas to provide maximum edge. Plots should be relatively small, long, and narrow. In extremely large plots, the central part may never be used.

## Management Suggestions For Selected Game Species

### Mourning Dove

In most areas, doves are managed by planting fields for dove shooting. Fields should be 5 to 10 acres. Large acreages can be planted if the field is long and relatively narrow. If hunters will be posted on both sides, it is best for the field to be at least 100 yards wide.

Fields near a good water supply are more successful than those far from water. This is especially true during dry years.

When planting in rows or with a drill, alternate the planted and bare areas. During the shooting period, bare areas should be disked or plowed. When broadcast planting, disc the strips before the season begins. Mechanically harvested, hogged-off, or mowed fields are attractive to doves. Whenever possible, stagger these practices to extend the time that the field is attractive.

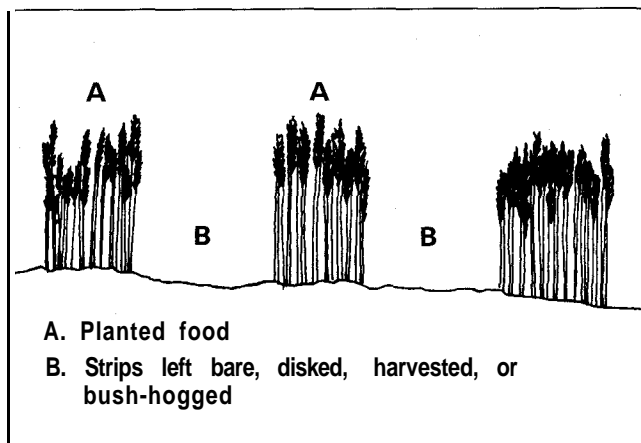

Figure 1. When planting in rows or with a drill, alternate planted and bare areas.

Limit shooting to once or twice a week and stop well before sunset. This gives the doves time to feed and roost near the field.

Plants which may be used in dove fields include an annual game-bird mixture, corn, corn and soybean mixture, brown-top millet, proso millet (one of the best overall), brown-top millet and grain sorghum mixture, and the various peas, sesame, and sorghum-soybean-millet mixtures.

## White-Tailed Deer

One of the most important aspects of deer management is a regulated harvest. Food is a problem in areas where deer are underharvested and populations are too high. Once an area's capacity to support animals has been reached, the excess deer must be removed to prevent damage to the habitat.

Woodlands can be managed for deer by prescribed burning at three- to five-year intervals and by timber harvesting and thinning. When cuttings are made, openings should be large enough to encourage the growth of the young, tender plants which deer eat. Whenever possible, leave mast trees (trees that produce fruits and nuts).

Food plots should be no less than 1 acre and may be 3 to 5 acres or more. Up to 10 percent of your total acreage can be put into food plots. Suggested plants include clovers, clover and small grain mixtures, corn, corn and soybean mixtures, oats, winter rye, rye grass, soybeans, cowpeas, and wheat.

## Ducks

Ponds used for duck production should be 3 to 5 acres. Leave up to one-third of the flooded area in trees—especially oaks—for mast, cover, and nesting. In general, farm ponds cannot be managed intensively for fish and ducks because duck food plants interfere with fish production.

Duck production ponds must have water control devices to allow drainage during the growing season and to allow flooding before hunting season. The pond should be flooded by the latter part of October. Ponds without water control can be managed for ducks by planting edges with Japanese millet. Best results can be expected in ponds with feathered edges which drop off very gradually.

It is possible to manage natural bodies of water for ducks, particularly beaver ponds. In early July, drain the pond and use a three-log drain in the dam

to prevent beavers from flooding the area. Plant Japanese millet on the exposed mud flats. Remove the drain in October, and the beavers will repair the dam and flood the millet.

The wood duck is the only duck which nests in any numbers in Alabama. Normally, it builds a nest in tree cavities. If cavities are absent, put up nest boxes. They should measure 12 by 12 by 20 inches with a 4-inch by 3-inch oval entrance hole.

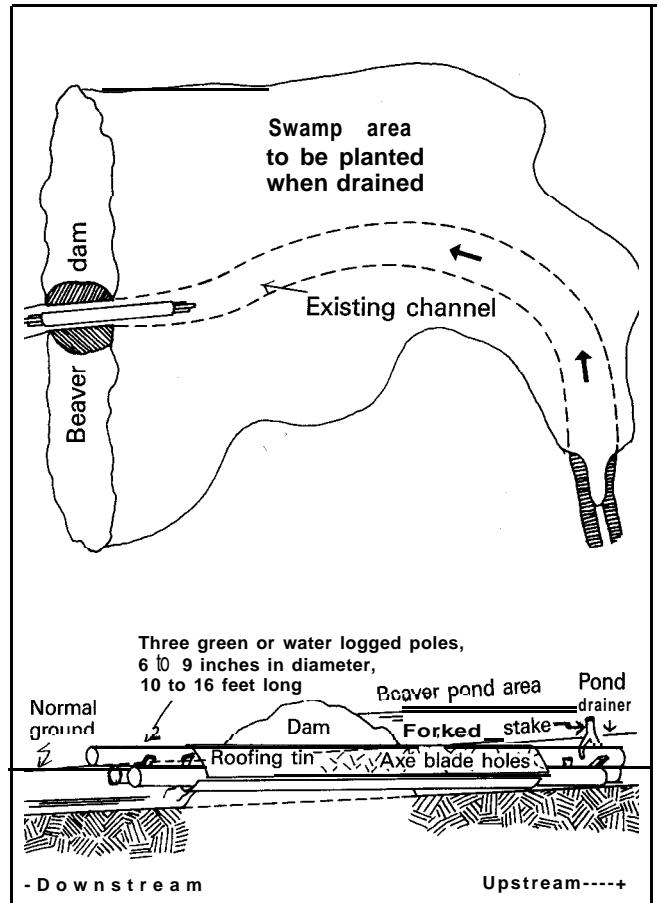

Figure 3. Beaver ponds can be managed for ducks.

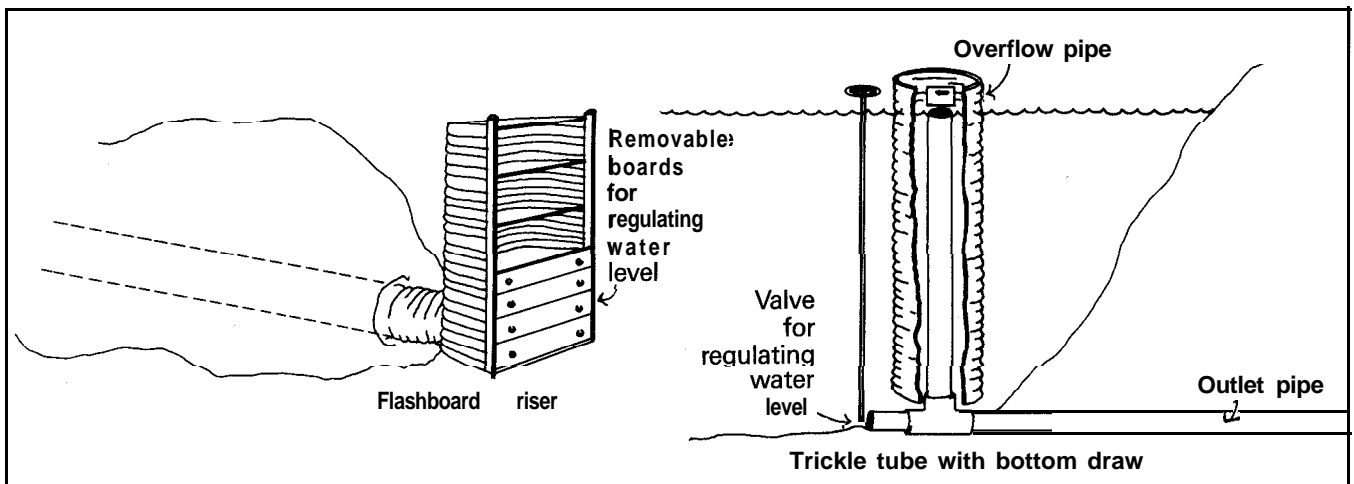

Figure 2. Water control devices.

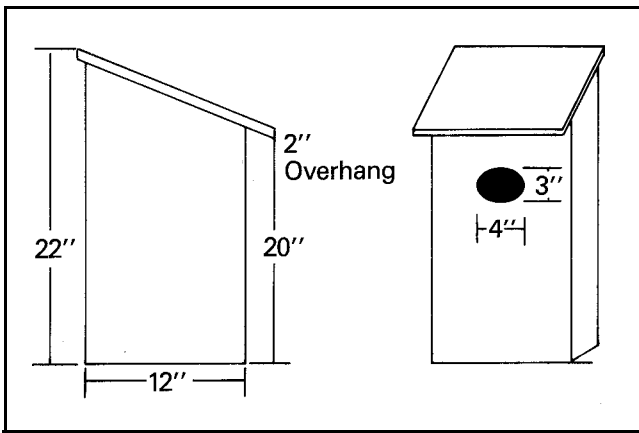

Figure 4. Nest box for the wood duck.

The shooting schedule depends on the size of the pond. However, there should be no more than three hunts per week. Schedule the shoots for morning hours only so ducks will return for roosting and will remain in the area longer.

Plants which can be used in duck ponds include corn, corn and soybean mixtures, brown-top millet, Japanese millet, brown-top millet and grain sorghum mixtures, sago pondweed, and nodding smart-weed.

### Bobwhite Quail

A primary technique for managing quail is to farm relatively small fields. When fields are separated by fence rows and allowed to grow native vegetation, they can be very good for bobwhites. Even when fields are large and fence rows nonexistent, certain techniques will increase the number of quail.

Disk field borders to encourage partridge pea and other native food plants. Corn and other row crops should be laid-by early to provide natural foods and brood cover. Pastures should have bicolor lespedeza borders outside the fences. If grazing pressure in a pasture is light, native lespedezas may invade and provide more food. Fertilizing natural

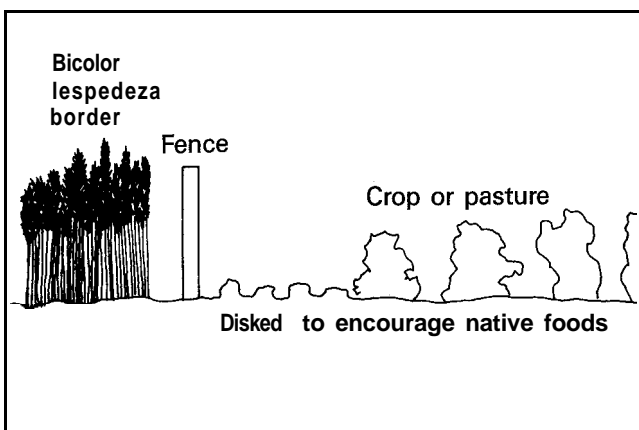

Figure 5. Relatively small fields can be farmed to manage quail.

areas with a high phosphorus fertilizer helps legumes produce abundant seeds.

Woodlots can be burned using Alabama Forestry Commission prescriptions. On fertile soils, burn annually from January to March. On infertile soils, it may be necessary to burn only every two years. If there is an annual burning regime on infertile soils, be sure to leave small patches unburned to provide a nesting cover. Before burning, contact your local unit of the Alabama Forestry Commission and adjoining landowners.

It is possible to provide both food and cover in a naturalistic manner by surrounding low-growing shrubs such as plums with bicolor lespedeza. Such plantings should be protected from burning.

If there is not enough food available, provide a 1/8- to 1/2-acre food plot for each covey. Make these plots long and narrow and locate them adjacent to a suitable cover. Quail can also be increased by planting small patches in woodlots and other large expanses of timber.

Plants that can be used in 1/8- to 1/2-acre food plots for quail include Egyptian wheat, partridge pea, millets, annual game-bird mixture, Florida beggar-weed, corn, corn and soybean mixtures, annual lespedezas (Korean, kobe, common), bicolor lespedeza, peas, sorghum, soybeans, and vetch. Food plots should be fertilized and limed according to soil test results.

### Rabbits

Given adequate food and cover, rabbits can maintain their numbers in spite of all their enemies. Every attempt should be made to retain as much natural cover as possible—brambles, fence rows, abandoned house sites, etc. Loose brush piles, 10 to 15 feet in diameter and no more than 3 to 4 feet high, can be left to provide cover. Where winter food is a problem, food plots can be used. Plots should be 1/8 to 1/2 acre.

Some of the plants which can be used for rabbits include annual game-bird mixtures, clovers, clover and grass mixtures, kobe lespedeza, oats, peas, rye, winter rye grass, vetch, and wheat.

### Squirrels

The only squirrel management technique available to most landowners is to ensure that mature hardwoods, particularly oaks and hickories, are left in the woodlot to provide food and dens. If the woodlot is adjacent to a field, plant corn along the border. Where den trees are absent or in short supply, artificial dens can be put up in the woodlot. These dens should measure 10 by 10 by 20 inches with a 2-1/2-inch diameter opening on the side.

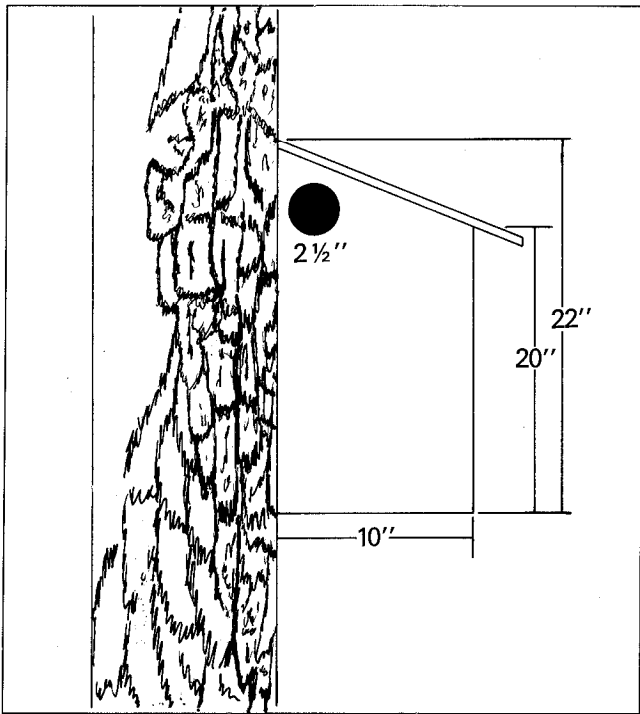

Figure 6. Artificial squirrel den.

## Turkeys

Turkeys require a greater area than many landowners have—usually 1,000 acres or more. However, you can provide areas of food and shelter on smaller tracts to attract turkeys during certain times of the year.

Woodlands should have hardwoods on the bottom and a mixture of hardwood and pine in the uplands with openings scattered throughout. At least half and up to two-thirds of the area can be in openings—natural or man-made, permanent or short-term. If there are trails or roads through the woodlands, these should be seeded with grass or clover and grass mixtures.

Prescribed burning can help maintain a relatively open understory. Burning should be on a three- to five-year cycle with no burning after March 1.

Man-made openings and food plots should be a minimum of 1 acre and ideally 3 to 5 acres. If deer are present, it may be necessary to make food plots and openings 2 to 10 acres to prevent plots from being eaten out.

Keep domestic poultry, including turkeys, chickens, and farm-raised game birds off wild turkey ranges. This prevents diseases from being transmitted to wild birds. Domestic turkeys could also interbreed with the wild turkeys, leading to a deterioration in the quality of the wild birds.

Two of the major factors which decrease turkey numbers are illegal hunting and feral and free-ranging dogs. Poaching and dogs must be controlled to preserve wild turkeys.

Plants suitable for turkey management include annual game-bird mixture, Bahia grass, chufa, clovers, clover grass mixtures, corn, corn and soybean mixtures, brown-top millet, millet and grain sorghum mixtures, oats, peas, winter rye grass, sunflowers, and wheat.

## Summary

All wildlife need food, cover, and water. These factors must be interspersed, not all of the food in one place and the shelter in another. Determine which of these three factors is not being met in an area and then plan to supply that particular need. This is the essence of wildlife management.

If you have any problems selecting plants or meeting plant requirements, contact your county Extension office.

## Native Plants Useful To Wildlife

### Trees And Shrubs

1. Bicolor lespedeza (*Lespedeza bicolor*)--Not native, but naturalized over large area. Excellent quail food.

2. Blackberry (*Rubus* spp.)--Berries are eaten by most wildlife.

3. Cherry, black (*Prunus serotina*)--Fruits are taken by quail, turkey, and particularly raccoon.

4. Dogwood, flowering (*Cornus florida*)--This plus various other dogwood berries are taken avidly by turkey, quail, squirrel, and a host of small birds.

5. Grape, muscadine, and other species (*Vitis* spp.)--Fruits are quite palatable and preferred by a number of species including deer, turkey, quail, and raccoon.

6. Hickory (*Carya* spp.)--Nuts are eaten by squirrel. Shells are usually too hard for other species.

7. Honeysuckle, Japanese (*Lonicera japonica*)--Outstanding winter deer browse; also eaten by rabbits. Fruits are eaten by quail and songbirds. Excellent cover for numerous species.

8. Oaks (*Quercus* spp.)--Acorns are eaten by most game except dove; very important for food and cover. Sawtooth oak (*Quercus acutissima*) is planted extensively as an almost fail-proof source of acorns. These acorns are as readily accepted as those of native oak species.

9. Persimmon (*Diospyros virginiana*)--Fruits are eaten by deer, raccoon, opossum, and turkey.

10. Pines (*Pinus* spp.)--Pine mast are used by quail, squirrel, turkey, and songbirds. Five to 15-year-old plantations can provide bedding area for deer. Clear-cut, site-prepared areas provide nesting and food for quail until about the second or third

year following preparation. Cut areas provide good browse for deer for the first five years.

11. Plums, wild (*Prunus* spp.)--Fruits are used by deer, turkey, bear, and raccoon; trees provide excellent cover.

12. Viburnums (*Viburnum* spp.)--Fruits are eaten by deer, raccoon, opossum, turkey, squirrel, and songbirds.

13. Waxmyrtle (*Myrica cerifera*)--Fruits are eaten by deer, quail, turkey, and songbirds.

14. Yaupon (*Ilex vomitoria*)--Excellent deer browse. Fruits are eaten by quail, turkey, raccoon, and songbirds.

### Upland Weeds And Herbs

1. Bahia grass (*Paspalum notatum*)--Excellent for turkey. Lightly mowed fields or openings provide excellent turkey brood range. Seed heads are avidly stripped.

2. Beggar-weed, Florida and perennial (*Desmodium* spp.)--Seeds are quail food.

3. Greenbriar (*Smilax* spp.)--Vines serve as palatable deer browse. Fruit is used by turkey, grouse, bear, and raccoon.

4. Lespedeza, common (*Lespedeza striata*)--Probably the best quail food in Alabama.

5. Lespedeza, other native species (*Lespedeza* spp.)--Seeds are quail food.

6. Milkpea (*Galactia* spp.)--A highly palatable quail food.

7. Partridge pea (*Cassia fasciculata*)--Seeds are quail food.

8. Pokeweed (*Phytolacca americana*)--Seeds are highly palatable food for dove, songbirds, raccoon, and bear.

9. Ragweed (*Ambrosia artemisiifolia*)--Seeds are eaten by dove, quail, and songbirds. A very important species.

### Aquatic And Marsh Plants

1. Arrow-aryum (*Peltandra virginica*)--Important for wood ducks, especially in beaver ponds.

2. Asiatic dayflower (*Aneilema keisak*)--Perhaps one of the most important duck food plants for the larger dabbling ducks-mallard and black--particularly in beaver ponds.

3. Barnyard grass (*Echinochloa crusgalli*)--Duck and quail food.

4. Bulrush, saltmarsh (*Scirpus maritimus*)--Outstanding duck food plant in brackish water.

5. Bulrush, soft-stem (*Scirpus validus*)--Highly palatable duck food.

6. Pondweed, sago, and other species (*Potamogeton* spp.)--Used by ducks.

7. Smartweed, Pennsylvania (*Polygonum pensylvanicum*)--Used by ducks and, to some extent, by doves.

8. Smartweed, swamp (*Polygonum hydropiperoides*)--Excellent duck food plant, particularly in beaver ponds.

9. Spikerush, dwarf (*Eleocharis parvula*)--Very good duck food in brackish water.

10. Tearthumb (*Polygonum sagittatum* and *arifolium*)--Important duck food in beaver swamps.

11. Watershield (*Brasenia schreberi*)--Good duck food, particularly for ring-neck ducks. Although mention is made that these plants serve as food for one species or another, most also provide cover for many wildlife species.

Recommended for Extension use in Alabama by Lee Stribling, *Extension wildlife Scientist*, Associate Professor, Zoology and Wildlife Science, Auburn University. This publication was adapted from *Selected Practices And Plantings For Wildlife*, University of Georgia Cooperative Extension Service Bulletin 733.

**For more information**, call your county Extension office. Look in your telephone directory under your county's name to find the number.

Issued in furtherance of Cooperative Extension work in agriculture and home economics, Acts of May 8 and June 30, 1914, and other related acts, in cooperation with the U.S. Department of Agriculture. The Alabama Cooperative Extension System (Alabama A&M University and Auburn University) offers educational programs, materials, and equal opportunity employment to all people without regard to race, color, national origin, religion, sex, age, veteran status, or disability.

UPS, 12M16, Rep. 12:96, ANR-485



## Alabama Planting Guide

CROPS	AREA*	PLANTING DATES	SEEDING RATES/ACRE	PLANTING DEPTH
Alfalfa	N	Aug. 25 - Oct. 1	30 lb.	1/4 inch
	C	Sept. 1 - Oct. 15		
Arrowleaf clover	N	Sept. 1 - Nov. 1	6 lb.	1/4 inch
	C	Sept. 1 - Nov. 1		
	S	Sept. 1 - Nov. 1		
Austrian winter pea	N	Sept. 1 - Oct. 15	40 lb.	1 - 2 inches
	C	Sept. 1 - Oct. 15		
	S	Sept. 1 - Oct. 15		
Bahia grass	C	Mar. 1 - July 1	20 lb.	3/4 inch
	S	Feb. 1 - Nov. 1		
Ball clover	N	Aug. 25 - Oct. 1	4 lb.	1/4 inch
	C	Sept. 1 - Oct. 30		
	S	Sept. 1 - Oct. 30		
Barley	N	Sept. 1 - Oct. 15	1-1/2 bu.	1 inch
	C	Sept. 1 - Oct. 30		
	S	Sept. 1 - Oct. 30		
Bermudagrass, all (sprigs)	N	April 1 - July 15	15 bu.	3/4 of sprig
	C	March 15 - July 15		
	S	March 1 - Aug. 15		
Bermudagrass, common (seed)	N	April 1 - June 15	5 lb.	1/4 inch
	C	March 15 - July 1		
	S	March 1 - July 15		
Bicolor lespedeza (seed)	N	March 1 - April 15	8 lb. (30-inch rows)	1/4 inch
	C	March 1 - April 1	16 lb. (broadcast)	
	S	Feb. 15 - March 30		
Bicolor lespedeza (seedlings)	N	Dec. 1 - March 1	7200 seedlings	2 - 4 inches above crown
	C	Dec. 1 - March 1	(3- x 2-foot spacing)	
	S	Dec. 1 - March 1		
Brown-top millet	N	May 1 - Aug. 1	8 lb. (30-inch rows)	1/2 - 1 inch
	C	April 1 - Aug. 15	20 lb. (broadcast for wildlife food)	
	S	April 1 - Aug. 15	30 lb. (broadcast for temporary vegetation)	
Bur clover	N	Sept. 1 - Sept. 30	20 lb. (hulled seed)	1/4 inch
	C	Sept. 1 - Oct. 15	125 lb. (burs)	3/4 inch
	S	Sept. 1 - Oct. 15		
Button clover	N	Sept. 1 - Sept. 30	20 lb.	1/4 inch
	C	Sept. 1 - Oct. 15		
	S	Sept. 1 - Oct. 15		
Caley peas	N	Sept. 1 - Oct. 30	50 lb.	3/4 inch
	C	Sept. 1 - Oct. 30		
	S	Sept. 1 - Oct. 30		
Chufa	N	May 1 - June 30	40 lb.	1 inch
	C	May 1 - June 30		
	S	May 1 - June 30		
Cowpeas (combine)	N	July 15 - Aug. 15	30 lb.	1 inch
	C	July 15 - Aug. 15		
	S	July 15 - Aug. 15		
Crimson clover	N	Sept. 1 - Sept. 30	20 lb.	1/4 inch
	C	Sept. 1 - Sept. 30		
	S	Sept. 1 - Oct. 30		
Dallis grass	N	March 15 - June 15	10 lb. (pure line seed)	1/4 inch
	C	March 1 - July 1		
	S	Feb. 1 - Aug. 1		
Dove proso	N	May 1 - June 15	8 lb. (36-inch rows)	1/4 - 1/2 inch
	C	May 1 - June 15	20 lb. (broadcast)	
	S	May 1 - June 15		

CROPS	AREA*	PLANTING DATES	SEEDING RATES/ACRE	PLANTING DEPTH
Egyptian wheat	N	May 1 - July 15	10 lb. (36-inch rows)	1 inch
	C	April 15 - July 15		
	S	April 1 - July 30		
Florida beggar-weed	S	Last cultivation of corn	12 lb. (broadcast)	Leave uncovered
Japanese millet	N	May 1 - July 31	8 lb. (36-inch rows) 20 lb. broadcast	1/2 inch
	C	May 1 - July 31		
	S	May 1 - July 31		
Johnson grass	N	April 1 - July 31	30 lb.	1/4 inch
	C	April 1 - July 31		
	S	April 1 - July 31		
Lespedeza (striate, kobe, and common)	N	Feb. 15 - March 31	30 lb.	1/4 inch
	C	Feb. 15 - March 31		
	S	Feb. 15 - March 31		
Lespedeza, Korean	N	Feb. 15 - March 31	25 lb.	1/4 inch
	C	Feb. 15 - March 31		
Millets (forage types)	N	April 1 - July 15	25 lb.	1/2 inch
	C	April 1 - July 15		
	S	April 1 - July 15		
Oats	N	Aug. 25 - Oct. 1	2-1/2 bu.	1 inch
	C	Sept. 1 - Oct. 30		
	S	Sept. 1 - Oct. 30		
Orchard grass	N	Sept. 1 - Nov. 1	15 lb.	1/4 inch
	C	Sept. 1 - Nov. 1		
Partridge pea	N	Feb. 15 - March 31	16 lb.	1/4 - 1/2 inch
	C	Feb. 15 - March 15		
	S	Feb. 1 - March 15		
Red clover	N	Aug. 15 - Oct. 15	10 lb.	1/4 inch
	C	Aug. 15 - Oct. 15		
Rye grass	N	Aug. 25 - Sept. 15	25 lb.	1/4 inch
	C	Sept. 1 - Oct. 15		
	S	Sept. 1 - Oct. 15		
Rye	N	Sept. 1 - Nov. 1	1-1/2 bu.	1 inch
	C	Sept. 15 - Nov. 15		
	S	Sept. 15 - Nov. 15		
Sorghum-sudan hybrids	N	May 1 - Aug. 1	20 lb.	1/2 inch
	C	April 15 - Aug. 1		
	S	April 1 - Aug. 15		
Sudan grass	N	April 15 - Aug. 1	25 lb.	1/2 inch
	C	April 15 - Aug. 1		
	S	April 15 - Aug. 1		
Sweet clover	N	Sept. 1 - Oct. 30	15 lb.	1/4 inch
	C	Sept. 1 - Oct. 30		
Vetches	N	Sept. 1 - Oct. 15	30 lb.	1 inch
	C	Sept. 1 - Oct. 15		
	S	Sept. 15 - Nov. 1		
Wheat	N	Sept. 1 - Nov. 1	1-1/2 bu.	1 inch
	C	Sept. 15 - Nov. 15		
	S	Sept. 15 - Nov. 15		
White clover	N	Aug. 25 - Nov. 15 Feb. 15 - April 1	3 lb.	1/4 inch
	C	Aug. 25 - Nov. 15 Feb. 1 - March 15		
	S	Aug. 25 - Nov. 15 Feb. 1 - March 15		

\*N=North Alabama; C=Central Alabama; S=South Alabama.